



GAI-TRONICS®
A HUBBELL COMPANY

Multi-Party Switch Kits and Harness Assemblies

PRODUCT INFORMATION UPDATE

Confidentiality Notice

This manual is provided solely as an operational, installation, and maintenance guide and contains sensitive business and technical information which is confidential and proprietary to GAI-Tronics. GAI-Tronics retains all intellectual property and other rights in or to the information contained herein, and such information may only be used in connection with the operation of your GAI-Tronics product or system. This manual may not be disclosed in any form, in whole or in part, directly or indirectly, to any third party.

General Information

The information in this publication applies to the following kits:

Kit Number	Description
12607-001	5-Party Line Switch Kit for Indoor Stations
12609-001	Harness Assembly/Switch for 5-Party Line Weatherproof Stations
12609-002	Harness Assembly/Switch for 5-Party Line Indoor Stations

Application

5-Party Systems

In response to customer feedback, GAI-Tronics has improved the 5-Party Line Switch. The switch has been improved to withstand twice as much pressure as the old switch. As a result of this change, the variable “stop” was removed. We hope that this change meets with your approval.

2, 3, and 4-Party Systems

GAI-Tronics has made available a resistor kit, Model 12509-002, designed for installation in 2, 3, and 4-party systems. Installation of this kit will eliminate the need for a “stop” on the party-line selector switch. When installed, this kit will also prevent feedback to the handset if the party-line selector switch is inadvertently turned to an unused party line.

Installation

Model 12607-001 5-Party Line Switch Kit for Indoor Stations

1. Remove the knob and the old switch. Use a $\frac{1}{16}$ -inch (#21) Allen wrench to loosen the 2 set screws in the selector knob. One screw is to the right of the party-line indicator; the other screw is in the end of the knob. After loosening the screws, lift the knob off, and set it and the screws aside. Save the knob.
2. Write down where all the wires and jumpers are connected.
3. Remove all the wires and jumpers from the old switch.
Note: Keep the wires as long as possible.
4. J-hook all the connections before soldering on the new switch.
This process will ensure a good mechanical connection. See Figure 1.

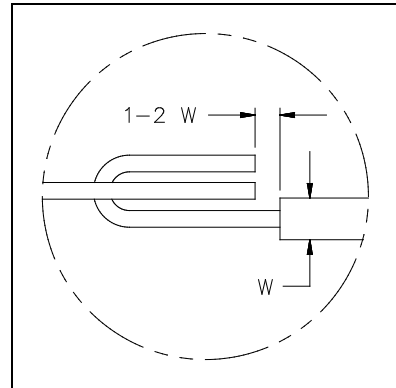

Figure 1. Proper J-Hook

Knob Installation

Suggested Tools

- $\frac{1}{16}$ -inch (#21) Allen Wrench
- Adjustable Torque Driver

1. Set adjustable torque driver to 8 inch-pounds.
2. Tighten the set screw at the tail end of the switch. Note the position of the shaft flat with respect to the tail of the knob. See Figure 2.
3. Tighten the remaining set screw.

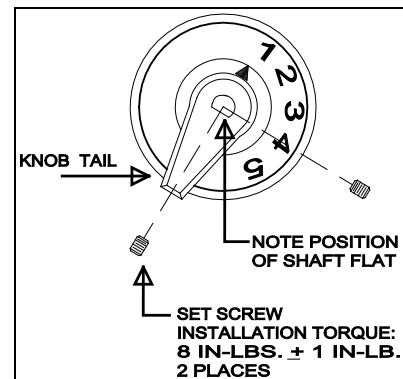

Figure 2. Knob Installation

Warranty

Equipment. GAI-Tronics warrants for a period of one (1) year from the date of shipment, that any GAI-Tronics equipment supplied hereunder shall be free of defects in material and workmanship, shall comply with the then-current product specifications and product literature, and if applicable, shall be fit for the purpose specified in the agreed-upon quotation or proposal document. If (a) Seller's goods prove to be defective in workmanship and/or material under normal and proper usage, or unfit for the purpose specified and agreed upon, and (b) Buyer's claim is made within the warranty period set forth above, Buyer may return such goods to GAI-Tronics' nearest depot repair facility, freight prepaid, at which time they will be repaired or replaced, at Seller's option, without charge to Buyer. Repair or replacement shall be Buyer's sole and exclusive remedy. The warranty period on any repaired or replacement equipment shall be the greater of the ninety (90) day repair warranty or one (1) year from the date the original equipment was shipped. In no event shall GAI-Tronics warranty obligations with respect to equipment exceed 100% of the total cost of the equipment supplied hereunder. Buyer may also be entitled to the manufacturer's warranty on any third-party goods supplied by GAI-Tronics hereunder. The applicability of any such third-party warranty will be determined by GAI-Tronics.

Services. Any services GAI-Tronics provides hereunder, whether directly or through subcontractors, shall be performed in accordance with the standard of care with which such services are normally provided in the industry. If the services fail to meet the applicable industry standard, GAI-Tronics will re-perform such services at no cost to buyer to correct said deficiency to Company's satisfaction provided any and all issues are identified prior to the demobilization of the Contractor's personnel from the work site. Re-performance of services shall be Buyer's sole and exclusive remedy, and in no event shall GAI-Tronics warranty obligations with respect to services exceed 100% of the total cost of the services provided hereunder.

Warranty Periods. Every claim by Buyer alleging a defect in the goods and/or services provided hereunder shall be deemed waived unless such claim is made in writing within the applicable warranty periods as set forth above. Provided, however, that if the defect complained of is latent and not discoverable within the above warranty periods, every claim arising on account of such latent defect shall be deemed waived unless it is made in writing within a reasonable time after such latent defect is or should have been discovered by Buyer.

Limitations / Exclusions. The warranties herein shall not apply to, and GAI-Tronics shall not be responsible for, any damage to the goods or failure of the services supplied hereunder, to the extent caused by Buyer's neglect, failure to follow operational and maintenance procedures provided with the equipment, or the use of technicians not specifically authorized by GAI-Tronics to maintain or service the equipment. **THE WARRANTIES AND REMEDIES CONTAINED HEREIN ARE IN LIEU OF AND EXCLUDE ALL OTHER WARRANTIES AND REMEDIES, WHETHER EXPRESS OR IMPLIED BY OPERATION OF LAW OR OTHERWISE, INCLUDING ANY WARRANTIES OF MERCHANTABILITY OR FITNESS FOR A PARTICULAR PURPOSE.**

Return Policy

If the equipment requires service, contact your Regional Service Center for a return authorization number (RA#). Equipment should be shipped prepaid to GAI-Tronics with a return authorization number and a purchase order number. If the equipment is under warranty, repairs or a replacement will be made in accordance with the warranty policy set forth above. Please include a written explanation of all defects to assist our technicians in their troubleshooting efforts.

Call 800-492-1212 (inside the USA) or 610-777-1374 (outside the USA) for help identifying the Regional Service Center closest to you.